



Whitehall Manufacturing®
Manufacturer of Healthcare and Rehabilitation Products since 1946

Ligature Resistant BestCare Faucets



WH3376-WSF
& WH3377-WSF



WH3376-WSF-SO
& WH3376-WSF-SO-BAT



WH3376-WSF-PPZ/-BAT
& WH3377-WSF-PPZ/-BAT



WH3375-SO/-BAT



WH3376 & WH3377



WH3376-PPZ/-BAT
& WH3377-PPZ/-BAT

INSTALLATION, OPERATIONS AND MAINTENANCE MANUAL



Table of Contents

	PAGE
Table of Contents	2
Prior to Installation	3
Valve to Deck Installation	4-7
Valve to Water Supply Installation	8
Pneumatic Valve Connections	9
-SO Sensor/-PPZ Programmable Piezo Pushbutton Connections . .	10
Troubleshooting for 9-Volt DC Sensor Operated Valves	11
Troubleshooting for Pushbutton Operated Valves	12
Repair Parts	13-15
Terms and Conditions	16
Warranty Information	17
Notes:	18-19



IMPORTANT

NOTICE TO INSTALLER:

- Check Material for any shortages or damage. Refer to shipping tally sheet when provides.
- Identify all component parts, and hardware: fasteners, brackets, clips, etc.
- Study job print carefully. Refer to job print for installation dimensions.

PRIOR TO INSTALLATION:

- All Whitehall fixtures are individually factory tested prior to shipping. Valves are tight and internal piping is free of all foreign material. Do not subject valve to freezing temperatures. Valve bonnets on brass valve bodies are installed by the factory with a 35 ft. lbs. torque load. Field installation should be similar. Note: Tightening beyond 35 ft. lbs. torque can distort valve body. Plastic valves and fittings should be hand tightened only. Prior to making installation, all connecting supply lines must be flushed and must be free of all foreign material - such as pipe dope, pipe chips, solder, sand, etc. If the system is disinfected using high chlorine concentrates, immediate flushing must take place. Whitehall will assume no responsibility for leaking valves or clogged showerheads - due to the presence of foreign material, or distorted valve bodies - due to excessive torque being applied to the bonnet.

INSTALLATION TOOLS:

- Installation tools are regularly furnished with each job when required, i.e., pin type screws, special anchoring exposed nuts, Shower-Ware and Wash-Ware Tools. Additional tools may be purchased from Whitehall.

CARE OF STAINLESS STEEL:

Stainless Steel should be kept clean at all times. If maintained, stainless steel surfaces will retain their new, clean polished appearance indefinitely. To remove water spots or rust spots, stainless steel cleaner/polish on a cloth is recommended. IF SPOTS ARE STUBBORN OR IF YOU WISH TO TREAT A SCRATCH; synthetic, abrasive, general purpose pads such as Scotch-Brite® are recommended. Apply the stainless steel cleaner/polish to the synthetic, abrasive pad and CAREFULLY rub out spot with cleaner/polish. Be sure to rub in the direction of the grain. Do not allow steel wool to come in contact with stainless steel. Steel particles can embed into the stainless steel surface and create rust. Fixtures with standing pools of water should be routinely flushed at unoccupied facilities to prevent rusting and build up that can cause damage or corrosion, such units may not be covered under the warranty.

After installation, these instructions should be given to maintenance personnel for future reference.

Notice to Installer:
If there are any questions about this product, please contact technical assistance with the job name & Sales order number.

JOB NAME:

SALES ORDER #:



BestCare Faucet WH3376-WSF & WH3377-WSF

- A- Prior to installing, remove Diaphragm Retainer (1), Hex Nut (2), Washer (3), and Spacer (4) from the Pushbutton Assembly.
- B- Fix the Pushbutton Assemblies to the Basin thru hole and fasten using the Spacer (4), Washer (3), Hex Nut (2) and Diaphragm Retainer (1).
- C- Remove the 1/4" OD x 1/4" NPT Push-In Fitting (5), Locknut (6) and Washer (7) from the Conical Faucet (8).
- D- Mount the Faucet (8) to the Basin. Install Washer (7) and Nut (6) to Faucet (8) from the Deck underside to secure. Assemble 1/4" NPT Push-In Fitting (5) to the Faucet Adapter (9).

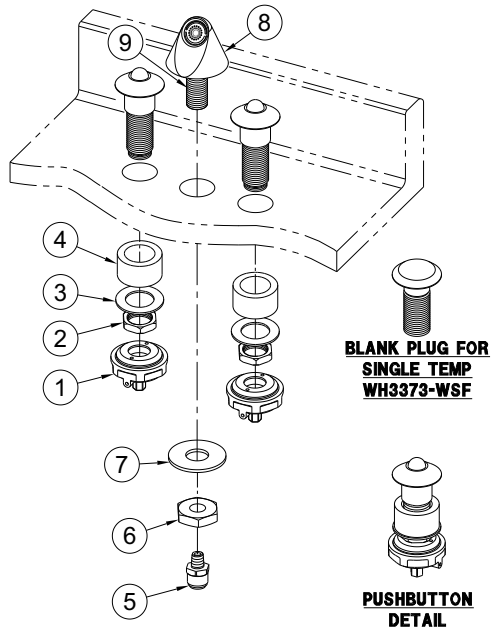

BestCare Faucet WH3376-WSF-SO & WH3376-WSF-SO-BAT

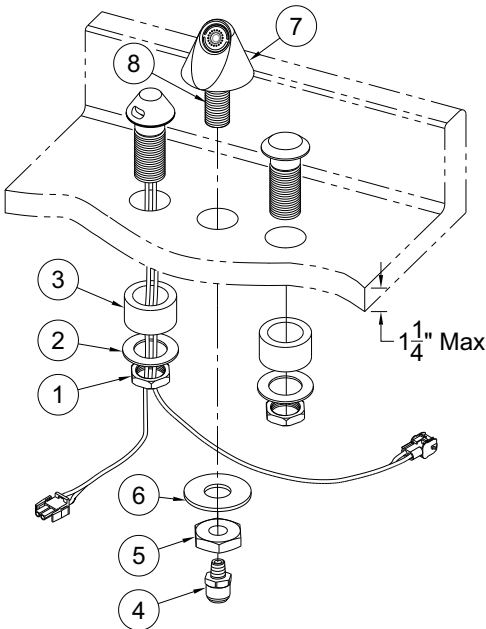

- A- Prior to installing, remove Hex Nut (1), Washer (2) and Spacer (3) from the Sensor Assembly Sleeve.
- B- Fix the Sensor Assembly to the Basin by passing Wires thru the hole and fasten using the Hex Nut (1), Washer (2) and Spacer (3).
- C- Remove the 1/4" OD x 1/4" NPT Push-In Fitting (4), Locknut (5) and Washer (6) from the Conical Faucet (7).
- D- Mount the Faucet (7) to the Basin. Install Washer (6) and Nut (5) to Faucet (7) from the Deck underside to secure. Assemble 1/4" NPT Push-In Fitting (4) to the Faucet Adapter (8).



BestCare Faucet WH3376-WSF-PPZI/-BAT & WH3377-WSF-PPZI/-BAT

- A- Prior to installing, remove Hex Nut (1), Washer (2) and Spacer (3) from the Piezo Button Sleeve.
- B- Fix the Piezo Button Assemblies to the Basin by passing Wires thru hole and fasten using the Hex Nut (1), Washer (2) and Spacer (3).
- C- Remove the 1/4" OD x 1/4" NPT Push-In Fitting (4), Locknut (5) and Washer (6) from the Conical Faucet (7).
- D- Mount the Faucet (7) to the Basin. Install Washer (6) and Nut (5) to Faucet (7) from the Deck underside to secure. Assemble 1/4" NPT Push-In Fitting (4) to the Faucet Adapter (8).

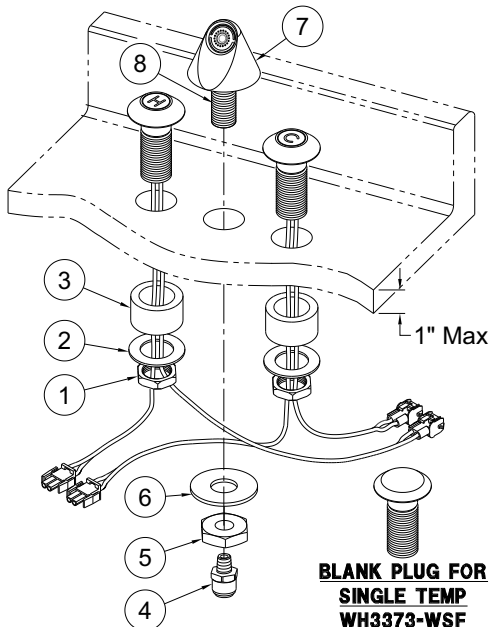

BestCare Faucet WH3375-SO/-BAT

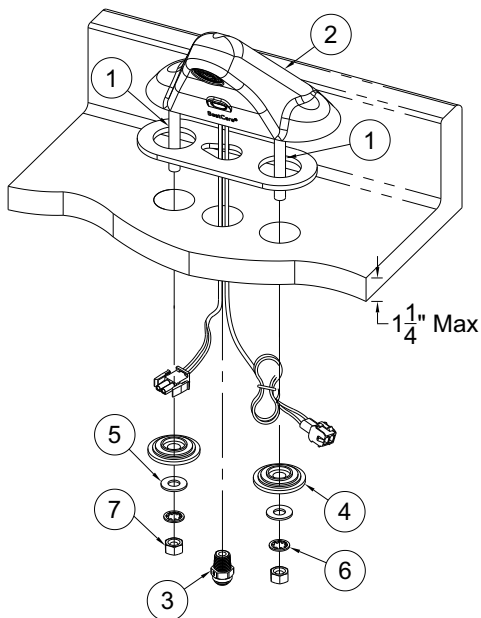

- A- Install the Threaded Rod (1) from the Hardware Package to the Faucet Assembly (2).
- B- Apply Teflon Tape to the 1/4" NPT Titting (3) then install into the Faucet Assembly.
- C- Feed the Faucet Assembly Wires through the center hole and mount Faucet Assembly (2) and Gasket on the Basin and fasten using the provided Step Washer (4), Flat Washer (5), Lock Washer (6) and Hex Nut (7).

Note:

1. Provide 3-hole, 4" Centerset Deck openings with $\phi 1"$ minimum to $\phi 1-1/2"$ maximum holes for Faucet installation.



BestCare Faucet WH3376 & WH3377

A- Prior to installing, remove the Pushbutton Escutcheon(s) (1) and Diaphragm Retainer Subassembly (2) from the Pushbutton Assembly. See detail.

B- Fix the Pushbutton Sleeves (3) to the Mounting Plate (4) using the Pushbutton Escutcheon (1).

C- Remove the 1/4" NPT Push-In Fitting (5), Locknut (6) and Washer (7) from the Conical Faucet (8).

D- Mount the Centerset Assembly to the Lavatory aligning the Pushbutton Sleeves (3) with Lavatory hole punching then add the Faucet Assembly (8) aligning the Anti-Rotation Pin (9) with the hole on the Plate (4).

E- Install the Washer (7) and Nut (6) to Conical Faucet (8) from the Deck underside to secure. Assemble 1/4" NPT Push-In Fitting Inlet (5) to Faucet Adapter (10).

F- Reassemble Pushbutton Diaphragm Retainer Subassembly (2) to Pushbutton Sleeves (3).

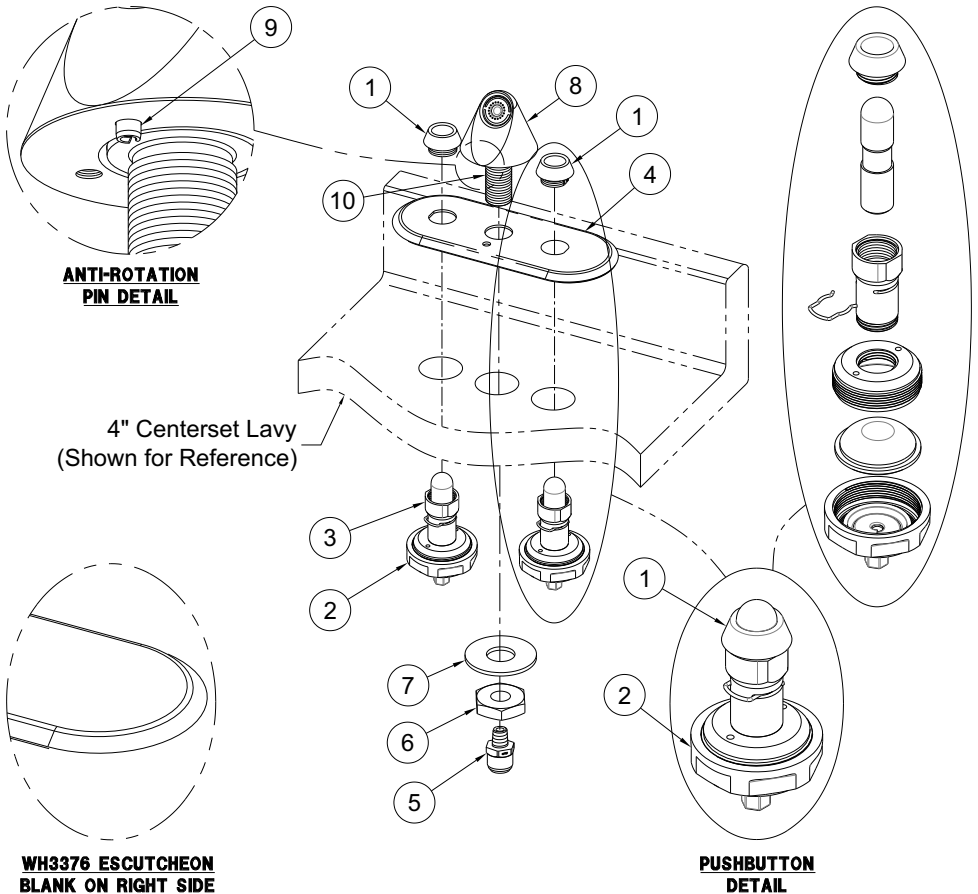

**WH3376 ESCUTCHEON
BLANK ON RIGHT SIDE**

**PUSHBUTTON
DETAIL**



BestCare Faucet WH3376-PPZI-BAT & WH3377-PPZI-BAT

- A- Prior to installing, remove Hex Nut (1) and Internal Tooth Lock Washer (2) from the Piezo Button. See detail.
- B- Fix the Piezo Button Assemblies to the Mounting Plate (3) by passing Wires thru opening, thread and tighten Hex nut (1) and Internal Tooth Lock Washer (2).
- C- Remove the 1/4" OD x 1/4" NPT Push-In Fitting (5), Locknut (6) and Washer 7 from the Conical Faucet (8).
- D- Mount the Centerset Assembly to the Lavatory by aligning the Button Assemblies with Ligature-Resistant Escutcheon Gasket (4) and Lavatory hole punching. Add the Faucet (8) aligning the Anti-Rotation Pin (9) with hole on Plate (3).
- E- Install the Washer (7) and Nut (6) to Faucet (8) from the Deck underside to secure. Assemble 1/4" NPT Push-In Fitting Inlet (5) to the Faucet Adapter (10).

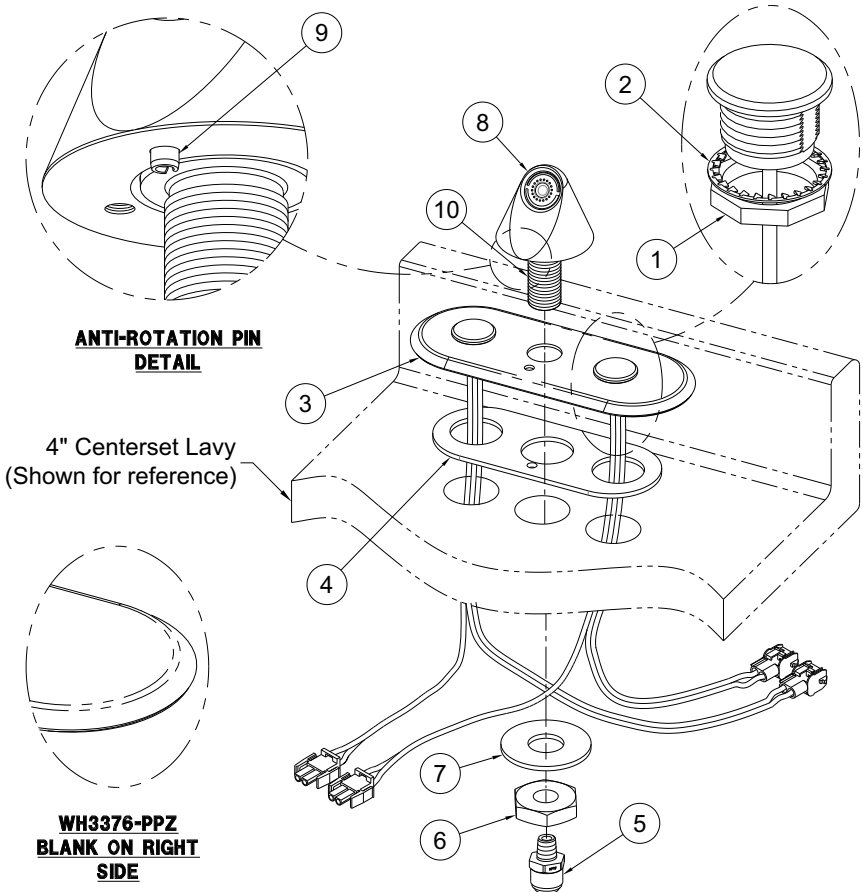



Valve to Water Supply Installation

! IMPORTANT

Before making up the supply connections, the supply lines must be flushed of all foreign material such as pipe dope, pipe chips, solder, sand, etc.

SINGLE TEMPERATURE METERING VALVE

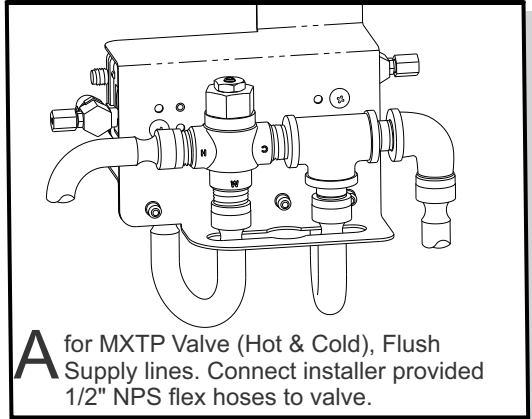
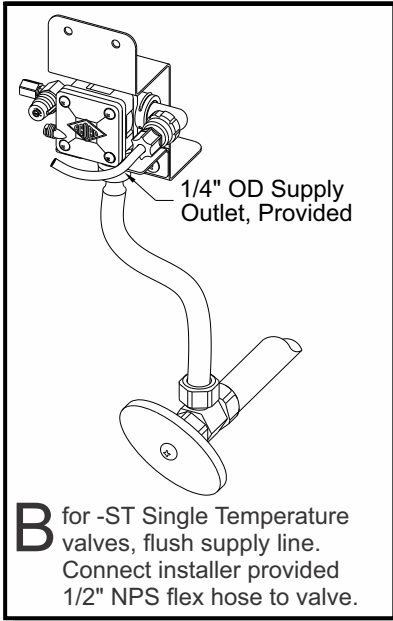

HOT & COLD METERING VALVE

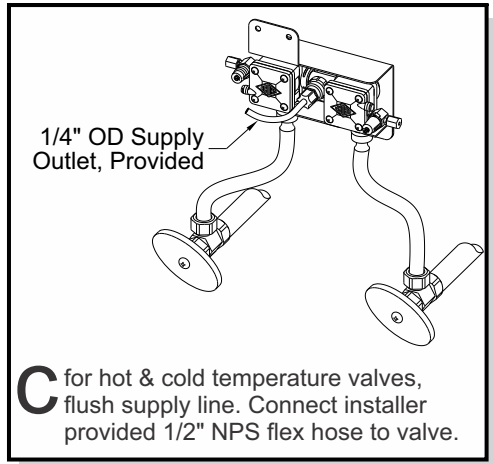

Valve Assembly Installation:

NOTE: Installation should be in accordance with accepted plumbing practices. Angle stops are recommended and is the responsibility of the installer

- 1) Connect hot and cold water to supply valve using 1/2" NPTE connections.
- 2) Connect outlet of tempering valve to spout(s) using 1/4" OD tubing and adapter.
- 3) Turn on hot and cold water supplies. If any leaks are observed, hand tighten connections as necessary to stop leaks before proceeding.

-MXTP VALVE ONLY

- 4) Turn on fixture and allow water to flow for 2 minutes. Measure water temperature at outlet. If water is not at desired temperature, adjust as necessary.



Pneumatic Valve Connections

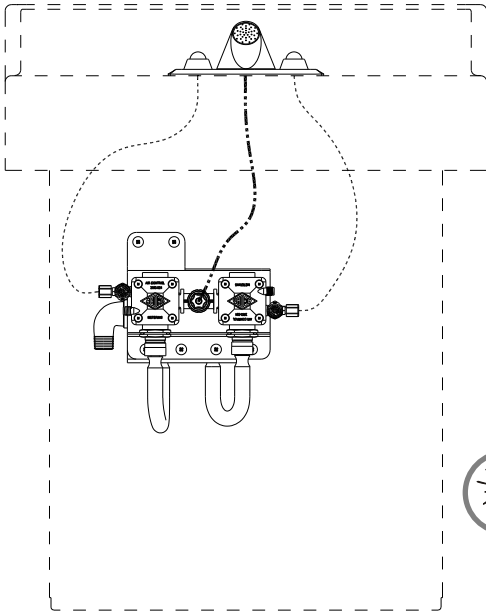

PNEUMATIC TUBING LINE KEY

..... 1/8" O.D. Air Tube

----- 1/4" O.D. Air Tube



Turn timing screw clockwise to increase timing.

Ferrule Nut

Timing Screw to adjust timing, turn timing screw

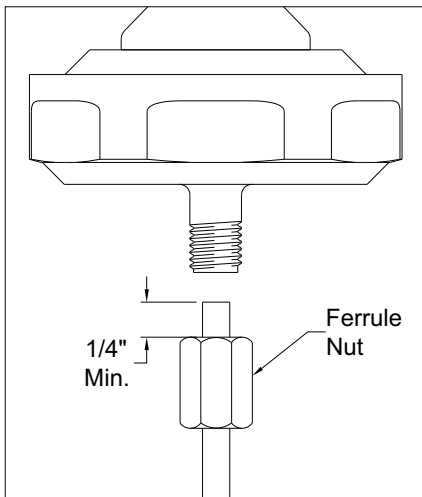
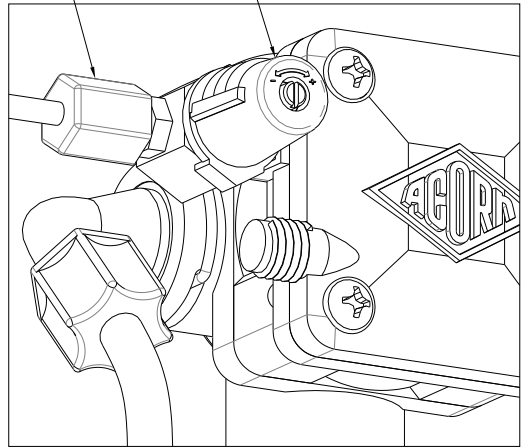

! IMPORTANT

Leave a minimum 1/4" of polyethylene tubing through the Ferrule Nut on the pushbutton assembly. This is necessary to ensure proper tubing connection. Do not over tighten Ferrule Nuts



-SO Sensor/ -PPZ Programmable Piezo Pushbutton Connections

WH3377-PPZ

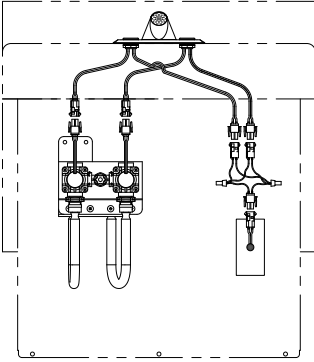

WH3376-PPZ/-SO

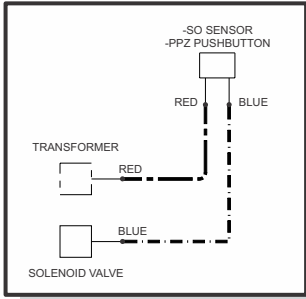
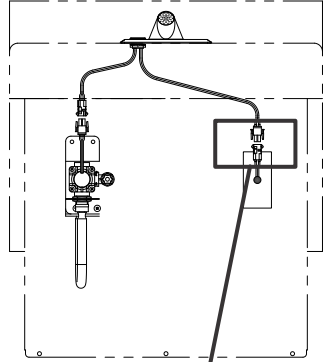

! IMPORTANT

Transformer must be plugged into a GFI protected circuit. Fixture must be earth grounded per N.E.C. or applicable codes.

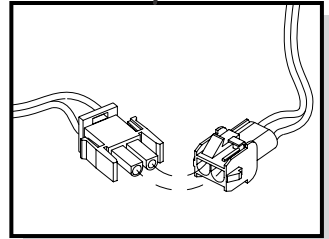

-SO Sensor Operation Range Adjustment

1. Make sure power supply is disconnected from sensor and make short circuit on red wires. See DETAIL A.
2. Connect power supply to sensor. Red light should be flashing.
3. Move hand in front of sensor to distance of 2" to 4" within 5 seconds and wait until red light flashes quickly.
4. Move hand to desired sensing distance. See DETAIL B.
5. Hold hand at desired sensing distance until red light stops flashing and solenoid activates. See DETAIL C.

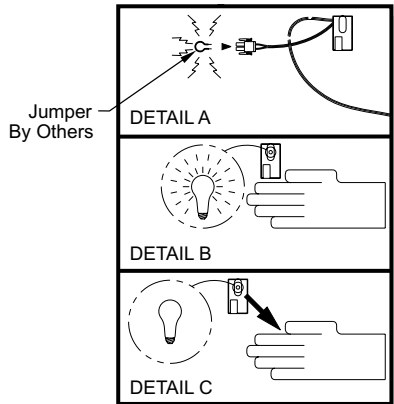



Troubleshooting for 9-Volt DC Sensor Operated Valves

Normal Valve Function: 9-Volt DC sensor operated valve has flow time of 90 seconds maximum. To reactivate, the user must move out of and return to the sensing area.

CONDITION: WATER DOES NOT FLOW



Indicators	Probable Cause	Solution
Sensor flashes continuously every 2 seconds when hands are within range.	Low battery warning	Replace battery
Sensor does not flash when the user's hands are within range.	Circuit breaker tripped.	Reset circuit breaker
	Battery completely used up.	Replace battery
	Defective 9V DC transformer	Replace transformer.
	Transformer polarity crossed	Replace transformer (sensor may be damaged and need replacement).
	Unit is in "Security Mode" after 90 seconds of constant detection.	Remove sources of detection and wait 30 seconds before checking.
	Range is too short.	Increase range.
	Range is too long.	Decrease range and wait 30 seconds.
	Sensor is picking up a highly reflective surface.	Eliminate cause of reflection and wait 30 seconds before checking.
Sensor flashes once when user's hands are within range.	Defective sensor.	Replace sensor.
	Stops or water main closed.	Open stops or water main.
	Bad sensor to solenoid connection.	Ensure wires make proper contact.
	Debris or scale in solenoid assembly.	Remove solenoid, pull out plunger and spring, and clean with scale remover solution or pressurized air.
	Debris or scale in diaphragm.	Remove diaphragm and clean
	Debris or scale in strainer.	Remove strainer and clean.

CONDITION: FALSE TRIGGERING; WATER FLOWS CONTINUOUSLY



Indicators	Probable Cause	Solution
Sensor flashes when user's hands are within range.	Debris or scale in diaphragm	Remove diaphragm and clean.
	Diaphragm is defective or torn.	Replace diaphragm.
Sensor does not flash when users hands are within range.	Sensor is dirty or covered.	Clean or uncover sensor and wait 30 seconds.
	Range too long or highly reflective surface, sunlight, bright lights etc. are triggering sensor.	Decrease range and wait 30 seconds. Eliminate cause of reflection or correct lighting problem.

CONDITION: WATER FLOWS CONTINUOUSLY BUT STOPS WHEN HANDS ARE WITHIN RANGE

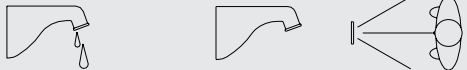

Indicators	Probable Cause	Solution
Water runs continuously when sensor not activated. Sensor flashes when hands are within range and water shuts off.	Solenoid polarity crossed.	Disconnect solenoid and reverse polarity.



Troubleshooting for Pushbutton Operated Vales

Normal Valve Function: Hand pushbutton operated valve has an adjustable flow time from 5 to 60 seconds.

CONDITION: WATER DOES NOT FLOW

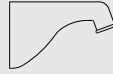

<i>Probable Cause</i>	<i>Solution</i>
Water main closed.	Open water main.
Checkstops closed.	Open checkstops.
Debris or scale in checkstop strainer	Remove checkstop strainer and clean.
Air leaks from 1/8" O.D. tubing or fittings.	Replace damaged tubing or fitting.
Pushbutton air diaphragm leaks.	Replace pushbutton air diaphragm.
Servomotor diaphragm center hole is blocked.	Remove blockage.
Servomotor upper diaphragm is damaged.	Replace servomotor upper diaphragm.
Low or no water pressure at supplies.	Increase water pressure to 30 PSI minimum.

CONDITION: WATER DRIPS, WON'T SHUT OFF



<i>Probable Cause</i>	<i>Solution</i>
Servomotor diaphragm offset hole is blocked.	Remove blockage.
Servomotor seat is damage	Replace servomotor seat.
Servomotor plate or diaphragm is obstructed.	Remove cause of obstruction.
Servomotor timer assembly is damaged.	Replace servomotor timer assembly.

CONDITION: REDUCED WATER FLOW

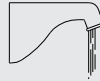

<i>Probable Cause</i>	<i>Solution</i>
Valve riser tubing is crimped.	Straighten valve riser tubing.
Debris or scale in checkstop strainer	Remove checkstop strainer and clean.
Blockage in valve flow control.	Remove blockage.
Low water pressure at supplies.	Increase water pressure to 30 PSI minimum.
Lime deposits in hot water pipes.	Remove lime deposits with appropriate cleaning solution.

CONDITION: PREMATURE WATER SHUT OFF

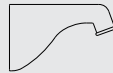

<i>Probable Cause</i>	<i>Solution</i>
Air leaks from 1/8" O.D. tubing or fittings.	Replace damaged tubing or fitting.
Pushbutton air diaphragm leaks.	Replace pushbutton air diaphragm.



Components & Repair Parts

Description	Part No.	Diagram
ELECTRICAL HARDWARE		
(-PPZ) PROGRAMMABLE PIEZO, HOT	0709-065-001	
(-PPZ) PROGRAMMABLE PIEZO, COLD	0709-066-001	
120VAC/9VDC PLUG-IN POWER SUPPLY	0710-735-001	
NANO SENSOR ASSEMBLY	2563-385-002	
2-STATION POWER CABLE ASSEMBLY FOR 9VDC POWER SUPPLY	0711-412-001	
6 AA BATTER PACK HOLDER ASSEMBLY	0710-358-001	
9VDC LATCHING SOLENOID ASSEMBLY	2563-326-001	



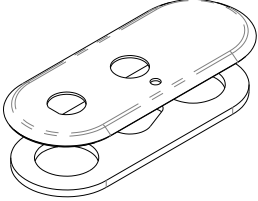
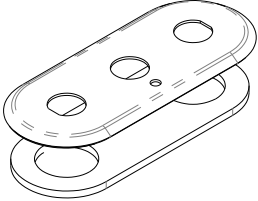
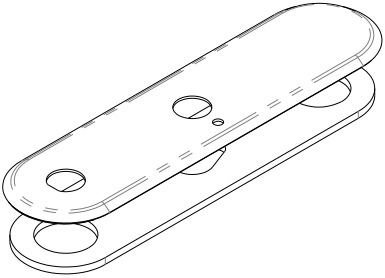
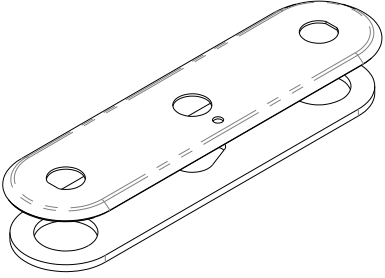

Components & Repair Parts

Description	Part No.	Diagram
ESCUTCHEON HARDWARE		
OBROND ESCUTCHEON AND GASKET, 4" (SINGLE TEMP)	2994-203-001	
OBROND ESCUTCHEON AND GASKET, 4" (HOT & COLD)	2994-204-001	
OBROND ESCUTCHEON AND GASKET, 8" (SINGLE TEMP)	2994-213-001	
OBROND ESCUTCHEON AND GASKET, 8" (HOT & COLD)	2994-214-001	

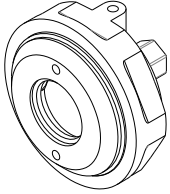
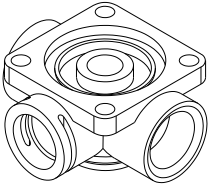
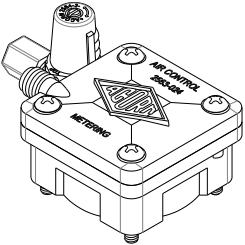

Components & Repair Parts

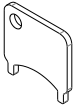
Description	Part No.	Diagram
PUSHBUTTON HARDWARE		
BACK OUTLET PUSHBUTTON ESCUTCHEON ASSEMBLY	2566-050-002	
VALVE HARDWARE		
SOLENOID METERING VALVE BODY	2570-027-000	
PNEUMATIC METERING VALVE ASSEMBLY	2563-020-002	
WATER DIAPHRAGM ASSEMBLY	2563-010-001	
NOZZLE HARDWARE		
VANDAL RESISTANT NOZZLE, MALE, 0.35 GPM	2998-111-000	
TOOLING HARDWARE		
SPANNER KEY	2998-055-199	



Terms and Conditions

Prices: Prices of the Company's Products are subject to change without notice. Quotations are conditioned upon acceptance within 30 days unless otherwise stated and are subject to correction for typographic or clerical errors. Sales order confirmation will be considered accepted by Buyer if objection is not submitted in writing to Whitehall Customer Service within (1) one week of receipt. The sales order confirmation is the governing document. All prices exclude sales, use, occupation, license, excise and other taxes in respect to manufacture or delivery. Unless a proper exemption certificate is furnished to the Company, all such taxes shall be paid by the Buyer to Company at the time of payment.

Term and Conditions of Payment: Terms of payment are **Net 30 from date of invoice**. Past due accounts will be subject to a 2% per month service charge from the date of the invoice. If any proceedings be instructed by or against Buyer under any bankruptcy or insolvency law, or if Buyer shall fail to make timely payment on this or any other order, or if, in the Company's judgment, Buyers financial situation justifies such action, the Company may, at its election, require payment in advance or cancel the order as to any unshipped item and require payment of its reasonable cancellation charges. If Buyer delays completion of manufacture, the Company may elect to require payment according to percentage of completion. Equipment held for Buyer shall be at Buyer's risk and expense. In all cases, regardless of partial payment, title to the Products shall remain in the Company until payment for the Products (including any notes given therefore) has been made in full. Should legal action be necessary to enforce payment of an unpaid invoice, the Buyer will assume full responsibility for any court costs and reasonable attorney fees. All orders are subject to credit check and approval prior to shipment. **Minimum invoice amount \$100.00.**

Return Goods Authorization: No materials shall be returned without a Return Goods Authorization (RGA) from Whitehall Customer Service. Returns must reference the RGA number and be shipped freight prepaid or the shipment will not be accepted. Credit issued for the return will apply only to future shipments and will be subject to a **35% handling charge**. Any cost associated with restoring product to saleable condition will be deducted from the credit and any outgoing freight charges paid by Whitehall. **Non-stock and custom fabrications are non-returnable.** RGA credit will not be issued for less than \$100.00 unless material is proven defective.

Delivery: Shipments are F.O.B. Factory, Industry, California or other designated shipping point determined by Whitehall. **FFA (full freight allowed) may be earned on all shipments over \$15,000.00 net; FFA applies to single shipments only. Any shipment or delivery dates quoted by the Company are estimated.** The Company shall be obligated to use reasonable efforts to meet such dates. **The Company will in no event be liable for any delays in delivery or failure to give notice of delay,** or for any other failure to perform hereunder due to causes beyond the reasonable control of the Company. Such causes shall include, but not be limited to acts of God, the elements, acts or omissions of manufacturers or suppliers of the Products or parts thereof, acts or omissions of Buyer or civil and military authorities, fires, labor disputes or any other inability to obtain the Products, parts thereof, or necessary power, labor, materials or supplies. The Company will be entitled to refuse to make, or to delay any shipments of the Products if Buyer shall fail to pay when due any payment owed by it to the Company, whether under this or any other contract between the Company and Buyer. Shipments are normally sent prepay or charge. A surcharge of \$8.00 handling will be added to **each** small parcel package shipment.

Claims and Shortages: F.O.B. factory shipments are the full responsibility of the Buyer. Losses or damages must be reported to the carrier immediately. Whitehall will file freight claims on FFA orders if the Buyer complies with the following within (5) five days of receipt of shipment; inspect shipment immediately, have delivering carrier inspect shipment, file inspection report with carrier, and send a copy to Whitehall. No claim for failure to receive shipment or shortage will be honored unless Whitehall is notified immediately upon receipt of invoice or within five working days of receipt of shipment, whichever is sooner.

Specifications: Approved submittals must be provided to Whitehall in writing before an order will be considered accepted. All products are subject to change without notice. Unless stated in the purchase order, material will be furnished per the design in effect at the time the order is filled. Field dimensions must be submitted in writing and are the full responsibility of the Buyer. Changes in specifications or cancellations must be submitted in writing to Whitehall for review, the Buyer will be subject to charges incurred due to the extent of the change or cancellation. **Non-stock and custom fabrications are not subject to cancellation.**



Whitehall Manufacturing®
Manufacturer of Healthcare and Rehabilitation Products since 1946

Mailing Address:

P.O. Box 3527 • City of Industry, CA 91744-0527 U.S.A

Physical Address:

15125 Proctor Avenue • City of Industry, CA 91746 U.S.A

Phone 800-782-7706 • 626-968-6681

Fax 626-855-4862

Web: www.whitehallmfg.com

E-mail: info@whitehallmfg.com

Field Service Information

Toll Free 800-743-8259

Local: 626-855-4866

Fax: 626-855-4863

E-mail: fieldservice@acorneng.com

MANUFACTURER'S WARRANTY

Go to www.whitehallmfg.com to fill out eWarranty Registration, keyword search: WARRANTY.

Whitehall Manufacturing Company warrants that its products are free from defects in material or workmanship under normal use and service for a period of one year from date of shipment. Whitehall's liability under this warranty shall be discharged solely by replacement or repair of defective material, provided Whitehall is notified in writing within one year from date of shipment, F.O.B. Industry, California.

This warranty does not cover installation or labor charges, and does not apply to materials which have been damaged by other causes such as mishandling or improper care or abnormal use. The repair or replacement of the defective materials shall constitute the sole remedy of the Buyer and the sole remedy of Whitehall under this warranty. Whitehall shall not be liable under any circumstances for incidental, consequential or direct charges caused by defects in the materials, or any delay in the repair or replacement thereof. This warranty is in lieu of all other warranties expressed or implied. Product maintenance instructions are issued with each fixture, and disregard or non-compliance with these instructions will constitute an abnormal use condition and void the warranty. If you have any questions or require technical assistance, please call 800-743-8219.

NOTICE TO KEEP ORIGINAL PACKAGING- Regarding warranty claims: customer must retain original packaging for one year upon receipt of product. If packaging is discarded, it is the customer's responsibility to provide adequate packaging. Any shipping claims that are a direct result of customer-provided packaging materials will be handled by the shipper.

Member of

MORRIS GROUP
INDUSTRIES

